

# Cogeneration / CHP Principles ©

An overview and introduction to the principles of cogeneration, with typical cycles and applications.



**Jim Noordermeer, P.Eng.**

Gryphon International Engineering Services Inc.

www.gryphoneng.com

## THE CASE FOR COGENERATION

**Cogeneration** is normally defined as:

“The simultaneous production of two or more forms of useful energy (usually electricity and heat) from a single fuel source.”

More recently, this concept is often referred to as **Combined Heat and Power (CHP)**.

In the early 1900's, because of the lack of a viable alternative, many small and large industries employed cogeneration for the simultaneous production of both process heat and electricity. With the subsequent development of large central electrical power generating stations and the creation of reliable electrical transmission and distribution systems, this initial interest in Cogeneration and CHP waned, as industries found it more economical to simply purchase electricity, while producing only their own process heat.

Today in a world of global competition, increasing power costs, economic expansion, transmission constraints, environmental concerns and the uncertainties of deregulation, many industries are once again turning to Cogeneration.

Some industries are increasing their current fuel usage or using a waste product as a fuel, for the purpose of generating electricity, either for self-generation (i.e. load-displacement) or for sale to a utility or other customer. The waste heat associated with this operation is then harnessed to provide process heat and/or more electricity. And in some cases, the waste heat associated with a process is being harnessed to generate electricity.

The net effect of either approach has been a new source of corporate revenue from the lowering of operating costs (i.e. savings) and/or from the sale of electricity. The economic incentive in some instances has been so great as to promote large electrical generation plants, sometimes in excess of the user's own requirements.

In recent years, there is a growing concern for the environment and production of greenhouse gases. Cogeneration produces electricity at much higher efficiencies than can be achieved by conventional central generating stations. Thus, to meet the Kyoto Protocol objectives, electricity production using cogeneration systems must be encouraged.

## BASIC COGENERATION CYCLES

The major equipment associated with a Cogeneration / CHP system or cycle traditionally includes one or more of the following:

- a) Steam generator or boiler.
- b) Steam turbine generator (STG).
- c) Gas turbine generator (GTG).
- d) Heat recovery steam generator (HRSG) or heat recovery boiler (HRB).
- e) Reciprocating spark-ignited Gas, Dual-Fuel or Diesel engine generator.

The manner in which the equipment is combined and used defines the type of cogeneration cycle.

### Topping Cycle

A **Topping Cycle** is one in which the primary purpose of the input fuel is to generate electricity, and the waste heat exhausted by this process is captured, and used in industrial processes or for district heating or cooling. Thus, the hierarchy of energy flow in a Topping Cycle is Fuel to Electricity to Process.

**Exhibit #1** illustrates the two most common topping cycles currently being employed in cogeneration installations.

The **First Case** shown on **Exhibit #1** is a Steam Generator & Steam Turbine installation. Here the fuel is fired in a steam generator and is used to produce steam. The steam in turn is expanded in a steam turbine which is used to rotate a generator and generate electricity.

Of the 100% of energy input (fuel) \*:

- a) ~ 15% of the fuel energy is converted to electricity (i.e. Power).
- b) Some 65% can be diverted to process uses (i.e. Heat).
- c) Some 15% is exhausted to atmosphere (i.e. lost) through the stack of the steam generator.
- d) A further 5% is lost in the form of auxiliary power uses in the cycle, and friction and radiated losses.

\* In the following examples and Exhibits, the energy content or heat value of the input fuel



## Cogeneration / CHP Principles ©

*will always be based upon the fuel's Higher Heating Value (HHV).*

The **Thermal or Cogeneration or CHP Efficiency** of this particular Topping Cycle, indicating the amount of useful energy forms provided by the input energy, is:

$$\begin{aligned}\text{Thermal Efficiency} &= \frac{65\% + 15\%}{100\%} \\ &= 80\%\end{aligned}$$

The amount of Process Heat compared to the amount of electrical Power produced can be expressed as a Heat-to-Power ratio. In this case the ratio is:

$$\begin{aligned}\text{Heat-to-Power Ratio} &= 65\% / 15\% \\ &= 4.3\end{aligned}$$

The **Second Case** shown on **Exhibit #1** is that of a Gas Turbine & HRSG installation. Here, the fuel is fired in the combustor of the gas turbine and used to generate electricity directly. The exhaust gas from the gas turbine is then used to supply the fundamental heat to a heat recovery steam generator. The HRSG generates steam which in turn is used to provide process heat.

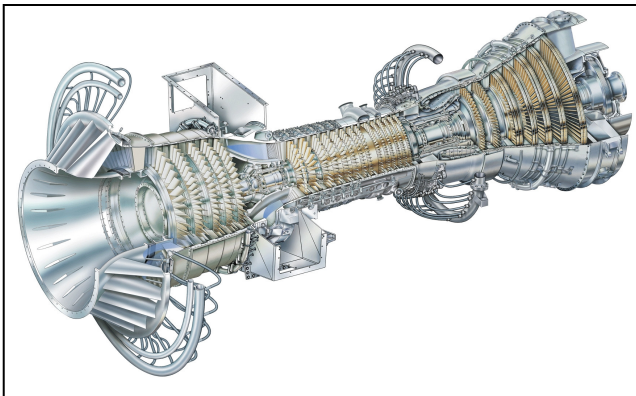

[www.gepower.com](http://www.gepower.com)

In this process and particular example, of the 100% energy in the input fuel:

- Up to 28% is converted to electrical Power.
- Nearly 50% provides process Heat.
- Some 17% is ultimately lost to atmosphere.
- A further 5% is utilized in auxiliary loads and is lost in friction and radiated losses.

The net **Thermal or Cogeneration or CHP Efficiency** of the second case, of  $[28\% + 50\%] / 100\% = 78\%$  is similar to the first steam-generator & steam turbine case. However, the **Heat-to-Power Ratio** of this second case is significantly reduced, to only  $50\% / 28\% = 1.8$ .

It should be pointed out that in these Topping Cycle examples, the input fuel could have been used to operate other prime movers, such as a gas or diesel reciprocating engines. Unlike the gas turbine, the waste heat in the engine jackets is captured through ebullient coolers which provides low grade steam or hot water to process. For this equipment, the overall Thermal Efficiency is in the order of 68% and the Heat-to-Power ratio is usually less than 1.0.

Also note – a more efficient gas turbine (e.g. a larger, 40% efficient unit) – generally has a lower exhaust temperature, and thus the HRSG would produce less Heat, resulting in a similar 75~78% thermal or cogeneration efficiency.

### Bottoming Cycle

A **Bottoming Cycle** is one wherein the fuel energy has primarily been used to provide process heat first. Waste heat from the process is then captured and used to generate electricity.

**Exhibit #2** illustrates a typical HRSG & Steam Turbine bottoming cycle, wherein the hierarchy is Fuel to Process Heat to Electricity. The waste heat left over from an industrial Heat process (e.g. furnace, dryers, thermal oxidizer, etc.) is directed to an HRSG, which uses the waste heat energy to generate steam. The steam is generally expanded through a steam turbine generator, to produce electricity.

In this Bottoming Cycle process, of the 100% energy in the input fuel, typically:

- Up to 50% of the initial fuel energy could end up as available waste heat to the HRSG/Steam Turbine.
- In the HRSG some 68% of the waste heat provided could be converted to steam, i.e. 34% of the 100% input fuel energy.
- Some 16% of the 100% input fuel energy is lost to the atmosphere from the HRSG's stack.
- Some 11% is ultimately converted to electrical Power via the steam turbine generator.
- Traditionally, the steam turbine is a condensing type, wherein 21% of the original fuel energy is lost to the atmosphere through a cooling medium, usually, water.
- Auxiliary power, friction and radiant losses account for a further 2% loss of the original fuel energy.

The resultant net **Thermal or Cogeneration or CHP Efficiency** of this particular Bottoming Cycle is typically  $[50\% + 11\%] / 100\% = 61\%$ . The **Heat-to-Power Ratio** of this Bottoming Cycle is  $50\% / 11\% = 4.5$ .

## Cogeneration / CHP Principles<sup>®</sup>

A variation of the above Exhibit #2 Bottoming Cycle would be to use part of the steam from the HRSG for further process use or for heating or cooling. This would increase the Thermal Efficiency of the cycle and increase the Heat-to-Power ratio. The actual quantity of electricity produced, however, would be reduced, and the cogeneration efficiency would be similar.

### Combined-Cycle Cogeneration

A Combined-Cycle Cogeneration plant is outlined in **Exhibit #3**. This cycle combines in tandem, the gas turbine topping cycle with the steam turbine bottoming cycle, with an energy flow hierarchy of Fuel to Electricity to Process to Electricity.

In this typical example, of the **100% energy** in the input fuel, typically:

- The gas turbine part of the cycle converts some 28% of the original fuel energy into electrical Power.
- GTG auxiliary power uses, and friction and radiant losses account for 5%.
- The HRSG converts some 50% of the input fuel energy to steam.
- The HRSG exhausts some 17% of the input fuel energy to the atmosphere.

The steam turbine part of the cycle is used both to generate electricity, and to provide steam to process via an internal "tap-off" (extraction). In this example, the resultant distribution of the 50% HRSG steam is:

- Some 14% to electrical Power via the steam turbine generator.
- Some 15% to process Heat use via the steam turbine's extraction.
- A further 20% loss to the atmosphere via the condenser cooling medium.
- A further 1% or so in auxiliaries and friction and radiant losses.

The net **Thermal Efficiency** of the illustrated cycle is about  $[28\% + 14\% + 15\%] / 100\% = 57\%$ , and the **Heat-to-Power Ratio** is about  $15\% / [28\% + 14\%] = 0.36$ .

Both the efficiency and Heat-to-Power ratio can be varied, by altering the amount of steam to process. The more steam to process, then the less to the condenser and more efficient the cycle.

More process steam (Heat) and electrical Power could also be produced by burning additional fuel via duct (supplemental) firing in the gas turbine exhaust on its way to the HRSG. This additional fuel

energy boosts all of the downstream outputs associated with steam production and the steam turbine.

*NOTE: a combined-cycle powerplant without a process steam host is not cogeneration / CHP.*

### PROCESS HEAT-TO-POWER RATIO

To assist in determining the most efficient cogeneration cycle for a given application, the Process Heat requirements and the Electrical Power requirements can be determined, and matched to a set of guidelines.

Thus, the **Process Heat-to-Power Ratio** can provide an indication of which cycle to employ. General optimization and equipment selection can then be undertaken.

**Exhibit #4** summarizes the Heat-to-Power ratios for various types of Topping Cycles\*, for various process steam pressures (\* bottoming cycles are not shown, since their design will generally be dictated by the type and amount of available waste heat which can be captured from the process).

With the **Steam-Generator & Steam Turbine** topping cycle, a Heat-to-Power Ratio as low as 4, or as high as 25 or above is possible. This large variation is primarily affected by the steam pressure of the steam-generator, i.e. the higher the operating pressure, the lower the ratio, since more electricity is produced, per pound of steam made.

The **Gas Turbine & HRSG** topping cycle is applicable in Heat-to-Power ratios of about 1.5 (unfired HRSG) to 10 (full supplementary-fired HRSG). The large fluctuation in this range is caused by the firing of additional fuel in the exhaust duct prior to the turbine's exhaust gas entry into the HRSG. The additional heat added in this manner can boost the process heat output, to match swings in the process load.

It is apparent that there is an overlap between these two types of topping cycles, and other factors are usually involved in the selection of one cycle over the other.

The primary objective of a **Combined-Cycle Cogeneration** scheme is electricity production. As such, much lower Heat-to-Power Ratios are encountered, often in the range of 0.2 to 2.0. In the extreme, the Heat-to-Power Ratio could become zero, when only electrical Power is produced in the pure combined-cycle case. In practice, however, a lower regulatory limit is usually encountered first.

## Cogeneration / CHP Principles ©

### COGENERATION CYCLE EFFICIENCY

#### General

In addition to Thermal or Cogeneration / CHP Efficiency discussed in each of the exhibits above, there are several other cycle efficiencies that are important to the project developer and/or regulatory bodies.

#### Cogeneration Efficiency

As a recap, Thermal or Cogeneration or CHP Efficiency is the overall efficiency of the power plant, and is simply calculated as the Useful Outputs divided by the Fuel Inputs.

As noted previously, the Cogeneration Efficiency of First case of Exhibit # 1 is [ electricity + heat ] / fuel = [65+15]/100 = 80%.

#### Fuel-Chargeable-to-Power (FCP) Heat Rate and Efficiency

Of frequent importance to the project developer or operator, are the Fuel-Chargeable-to-Power (FCP) Efficiencies and Heat Rates, on an instantaneous, monthly or annual basis, and can assist the proponent in determining appropriate cost allocation(s) for the plant's electrical product. A FCP Heat Rate is commonly defined and calculated as follows:

$$\text{FCP HR} = \frac{[\text{All Fuel} - \text{Boiler Fuel Saved}]}{\text{Power Output (kW)}} \text{ (btu/hr)}$$

Or alternatively, on an annual (or monthly) basis:

$$\text{FCP HR} = \frac{\text{Year's "Fuel - Saved Boiler Fuel" (btu)}}{\text{Year's Electrical Output (kW.hr)}}$$

The cost of fuel, for instance in \$/mmbtu, can be multiplied by the FCP Heat Rate to obtain the fuel cost component of an electricity price.

Note that "FCP Efficiency", in %, is the inverse of the above formulae (with appropriate conversions of kW to btu/hr or vice versa), or simply equal to 3413 divided by FCP Heat Rate.

As an example, the approximate FCP Efficiency of the First Case of Exhibit #1, assuming an existing boiler HHV efficiency of 75% is as follows:

$$\begin{aligned} \text{FCP Eff'y} &= \frac{28\%}{[100\% - [50\%/75\%]]} \\ &= \frac{28\%}{[100\% - [66.6\%]]} \\ &= 84\% \end{aligned}$$

$$\text{FCP Heat Rate} = 3413/84\% = 4063 \text{ btu/kW.hr}$$

If gas cost is \$9/mmbtuHHV, the FCP cost component of the electricity price is potentially 3.7

c/kW.hr.

Compare this to 28%/100% = 28% = 12,190 btu/kW.hr and 11 c/kW.hr for the same gas turbine unit in simple-cycle (no heat recovery or cogeneration) configuration.

#### Class 43.1 Heat Rate

In Canada, the applicable tax classification for cogeneration facilities and equipment is **Class 43.1**, which defines a minimum plant efficiency target which is required to allow accelerated depreciation of portions of the cogeneration equipment.

The required Efficiency or Heat Rate hurdle is 6,000 btu/kw.hr, based on the fuel higher heating value HHV. For non-renewable (i.e. fossil) fuels the Class 43.1 Heat Rate has been defined as:

$$\frac{[(1) - (2)] - \frac{[(K) \times (2) \times (4)]}{[(2) + (3T)]}}{(3E)}$$

Where the equation terms are defined as follows:

(1) = Non-Renewable Fuel Input, in btu/hr<sub>HHV</sub>.

(2) = Useful Thermal Output, in btu/hr.

(3E) = Electrical Gross Output, in kW.

(3T) = Electrical Output, converted to btu/hr using 3,413 btu/kw.hr.

(4) = Plant Losses, in btu/hr, derived by the following equation:

$$(4) = (1) - [(2) + (3T)]$$

(K) = Unity.

The above initial equation reduces to:

#### Class 43.1 Heat Rate (btu/kW.hrHHV) =

$$\frac{\text{Fuel Heat Input (btu/hr}_{\text{HHV}})}{\text{Gross Electrical Output (kW)} + \frac{\text{Net Process Heat (btu/hr)}}{3413 \text{ (btu/kW.hr)}}$$

For steam being sent for process use, the Net Process Heat would be the total heat content (in btu/lb) of the steam being sent to the process, minus, the total heat in the condensate return (in btu/lb).

Cogeneration plants which qualify for Class 43.1, whether constructed by an approved Industrial User or a Developer, may depreciate a portion of the plant based on a 30% declining balance, thus enhancing the plants economic return.

## Cogeneration / CHP Principles ©

### TYPICAL COGENERATION APPLICATIONS

The use of cogeneration has become common place in the United States and is quickly gaining favour within Canada.

Following are some typical heat balances of cogeneration facilities.

#### Steam-Generator and Back-Pressure Steam Turbine Application

**Exhibit #5** illustrates a **Steam-Generator & Backpressure Steam Turbine** cogeneration scheme that has been employed in alumina plants, pulp and paper applications and small industrial installations.

This system has an extremely high thermal efficiency, since all of the steam that makes it's way through the steam turbine is subsequently usefully employed as Heat in the process.

Some production of electrical Power has also occurred providing the system with an overall thermal power efficiency of **80%** and a Heat-to-Power Ratio of **10**.

This particular scheme is particularly attractive when existing steam-generators exist, which produce steam at a high enough pressure.

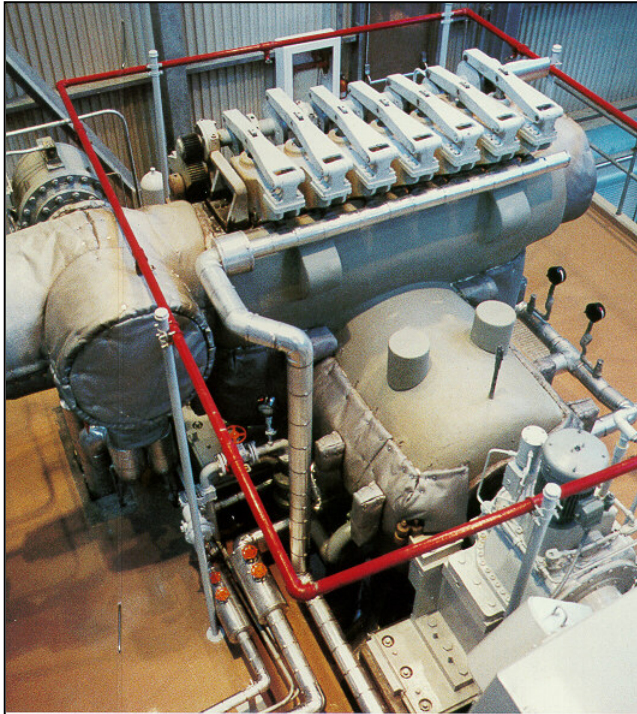

[www.dresser-rand.com](http://www.dresser-rand.com)

#### Steam-Generator and Condensing Steam Turbine Application

**Exhibit #6** illustrates a **Steam Generator & Condensing Steam Turbine** cogeneration scheme that has the same process Heat requirements (180,000 lb/hr at 150 psig) as the previous exhibit, only the electrical Power output has been increased from 6,000 kW to 13,000 kW.

To increase the electricity production, the amount of fuel energy input to the system was increased, thus raising the steam output of the steam generator from 200,000 to 280,000 lb/hr. A portion of the steam is now expanded in the steam turbine to sub-atmospheric pressure and condensed.

The maximum overall thermal efficiency of this condensing cycle is reduced to **66%**, since the latent heat contained in the steam passing through to the condenser is essentially wasted. The Heat-to-Power Ratio is correspondingly lower, at **4.6**.

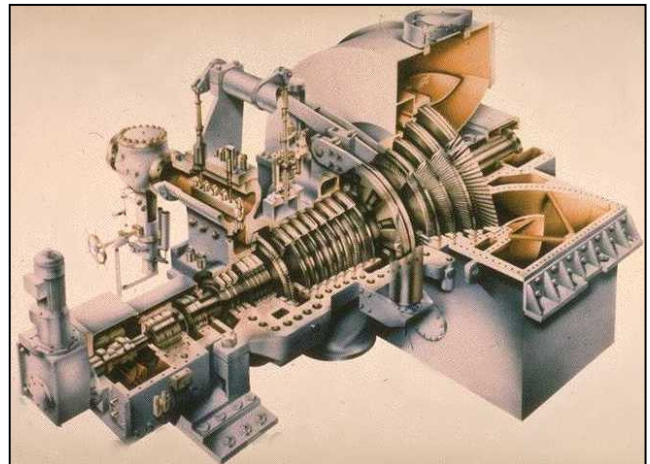

This particular cogeneration scheme has found application in the petrochemical and the pulp and paper industries, again particularly when existing steam generators exist.

#### Combined-Cycle Cogeneration

**Exhibit #7** illustrates a typical **Combined-Cycle Cogeneration** heat balance for the cogeneration application frequently promoted by developers for use at industrial sites.

This scheme is intended to maximize the electrical output for the developer, with a relatively small process steam requirement.

The limitations on this size of installation, in the United States, was governed by PURPA and as such these applications were viewed as PURPA configuration.

In Canada, the Class 43.1 Heat Rate requirements also limit the size of the cogeneration facilities for a given steam host size.



## Cogeneration / CHP Principles ©

The thermal efficiency of this particular cogeneration scheme is in the order of **48%** and the Heat-to-Power Ratio is about **0.4**.



Lake Superior Power – 2 x GE LM6000PA + GE STG

### Gas Turbine and HRSG Application

**Exhibit #8** illustrates a typical **Gas Turbine & HRSG** cogeneration application suitable for a small to medium process plant applications such as a food or material processing plants, or a brewery.

These plants have a very high overall thermal efficiency, and by the addition of supplementary firing in the exhaust gas duct between the gas turbine and the HRSG, can also have a high Heat-to-Power Ratio.

The thermal efficiency of this particular cogeneration application is in the order of **80%** and the Heat-to-Power Ratio is about 4.4.



Whitby Cogeneration Plant – RR Trent + IST OTSG

**The above exhibits and examples are only typical of the many possible opportunities.**

**Every cogeneration application is different, due to differing technical, infrastructure, financial, economic and/or operational philosophy reasons.**

### SUMMARY

Based on the preceding illustrations, a potential Industrial User of cogeneration / CHP can define the cycle that is most applicable to their use.

Once decisions are taken on the hierarchy of the cycle and process heat production, cogeneration facilities can be sized to either meet average or peak process heat requirements or peak or average electrical requirements

An Industrial User must determine if the **primary objective** of his cogeneration facility will be the production of process Heat or of electrical Power. A second consideration is the **responsibility** for process heat production, i.e. does he wish to be the recipient of process heat from a third-party, or does he wish to control it himself?

A very significant variable in any industrial user's analysis will be whether or not a third-party may be involved in the development of the cogeneration facility. Once this path is followed, electricity production for sale to a utility becomes paramount to the Developer. The production of process steam for the industrial user becomes a mandated necessity to justify that the maximum size facility that can be developed.

The net result of either of the above approaches from an Industrial User's point of view is that he can direct a project that meets his process steam and/or electricity requirements more cost effectively. For him, this translates into lower operating and production costs, and a more competitive product.

FUEL → ELECTRICITY → PROCESS HEAT

### A. STEAM GENERATOR/STEAM TURBINE

THERMAL EFFICIENCY = 65 + 15 = 80%  
 HEAT TO POWER RATIO = 65/15 = 4.3

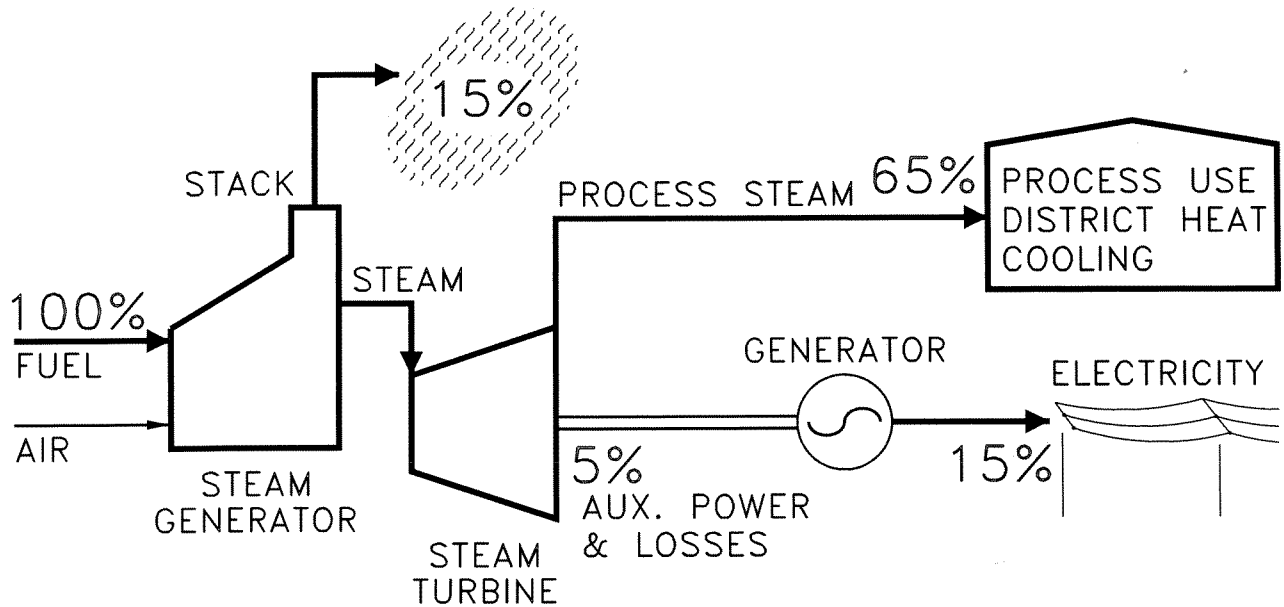

### B. GAS TURBINE/HRSG

THERMAL EFFICIENCY = 50 + 28 = 78%  
 HEAT TO POWER RATIO = 50/28 = 1.8

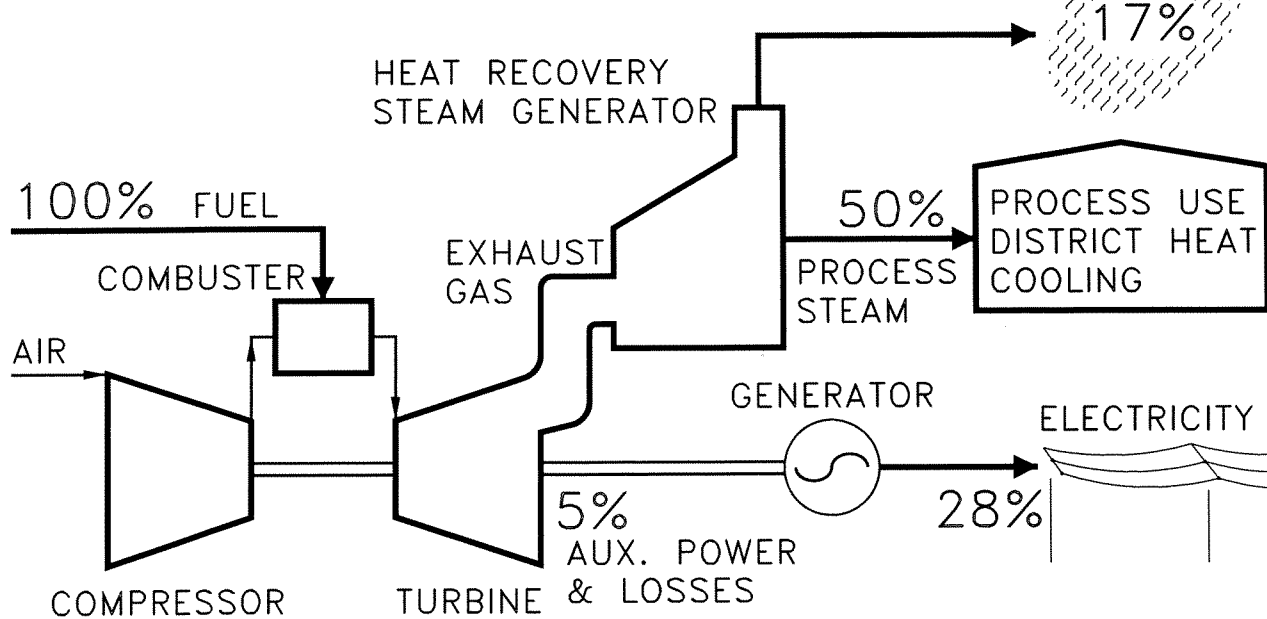

GRYPHON  
 INTERNATIONAL ENGINEERING SERVICES INC.

## TOPPING CYCLES

ALL EFFICIENCIES ARE HHV

JAN. 2000

COGENERATION PRINCIPLES  
 EXHIBIT 1

FUEL → PROCESS HEAT → ELECTRICITY

# HRSG/STEAM TURBINE

THERMAL EFFICIENCY = 50 + 11 = 61%

HEAT TO POWER RATIO = 50/11 = 4.5

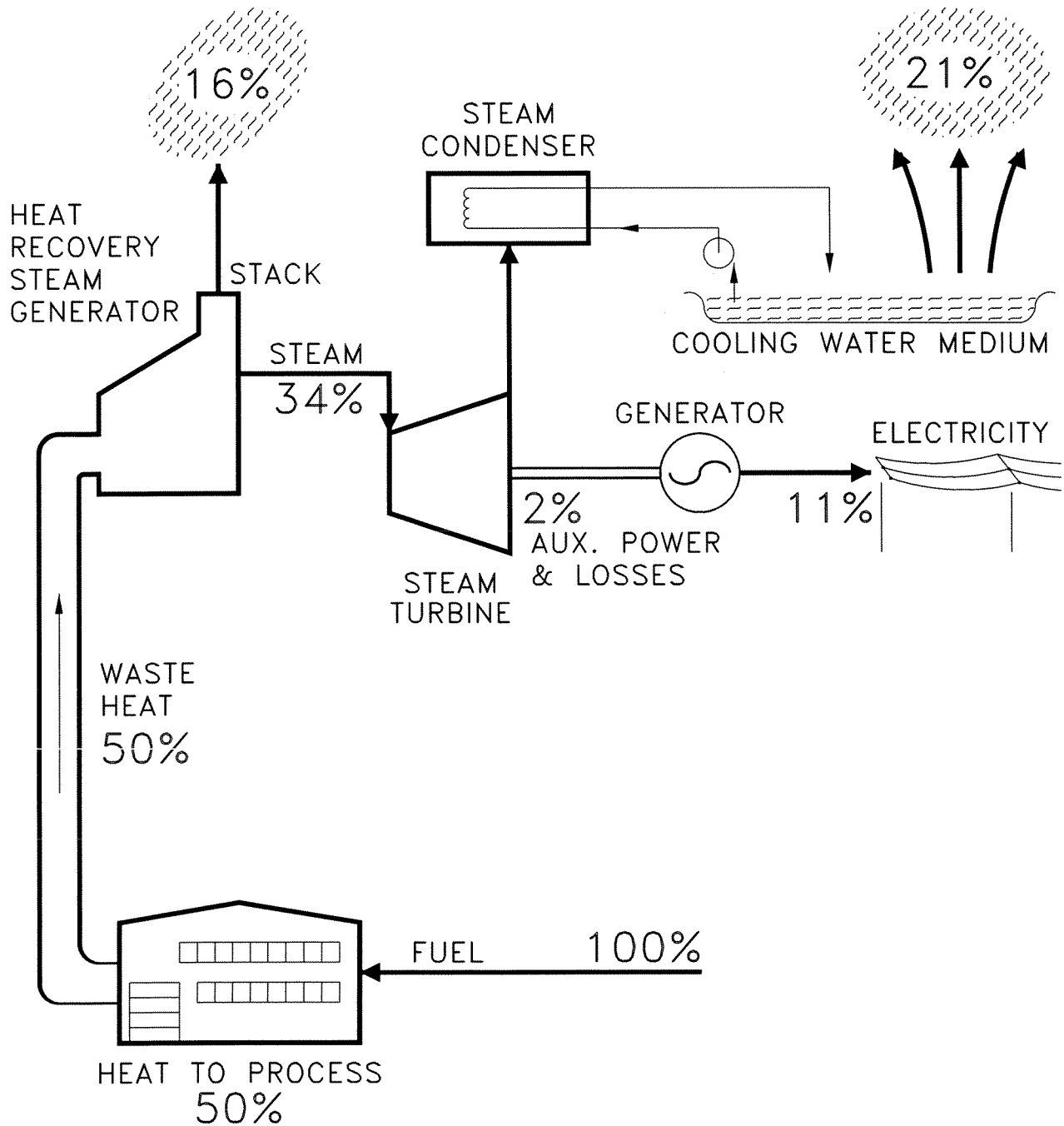

GRYPHON  
INTERNATIONAL ENGINEERING SERVICES INC.

## BOTTOMING CYCLE

ALL EFFICIENCIES ARE HHV

JAN. 2000

COGENERATION PRINCIPLES  
EXHIBIT 2

FUEL → ELECTRICITY → PROCESS → ELECTRICITY

# GAS TURBINE/HRSG/STEAM TURBINE

THERMAL EFFICIENCY = 28 + 15 + 14 = 57%  
 HEAT TO POWER RATIO = 15/(28 + 14) = 0.36

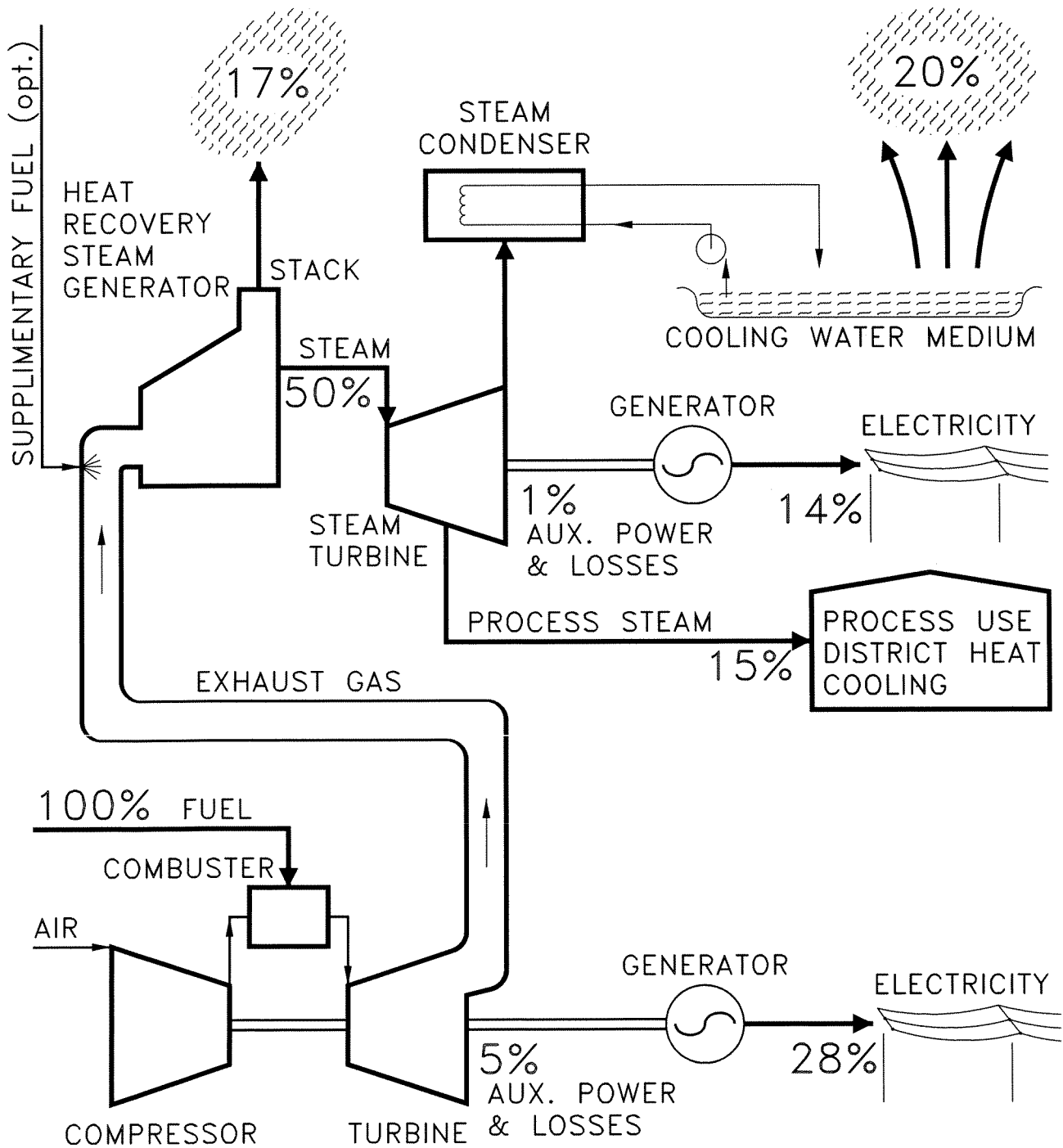

**GRYPHON**  
 INTERNATIONAL ENGINEERING SERVICES INC.

## COMBINED CYCLE COGENERATION

ALL EFFICIENCIES ARE HHV

JAN. 2000

COGENERATION PRINCIPLES  
 EXHIBIT 3

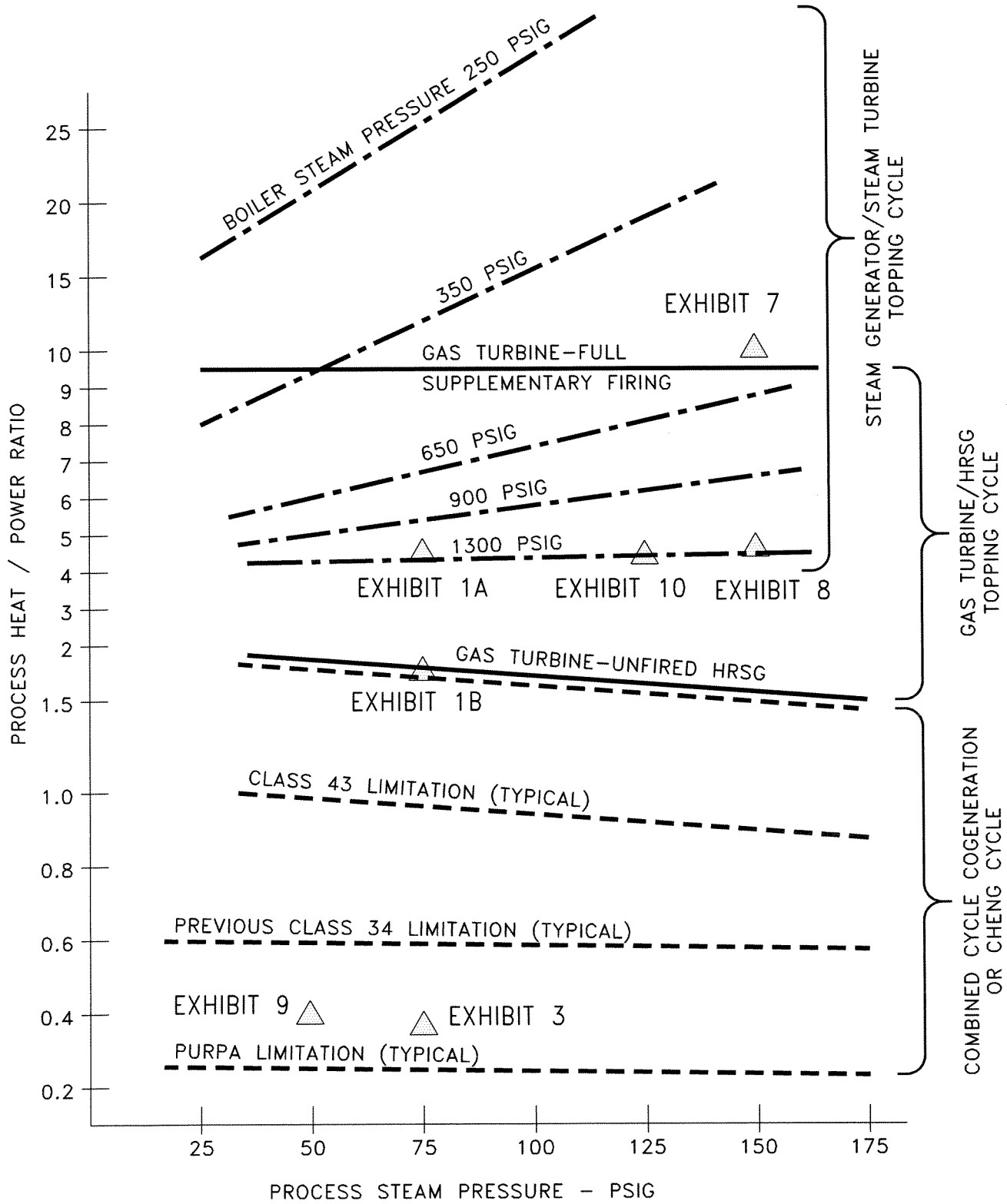

**GRYPHON**  
INTERNATIONAL ENGINEERING SERVICES INC.

# HEAT TO POWER RATIOS

JAN. 2000

COGENERATION PRINCIPLES  
EXHIBIT 4

# STEAM GENERATOR/BACKPRESSURE STEAM TURBINE

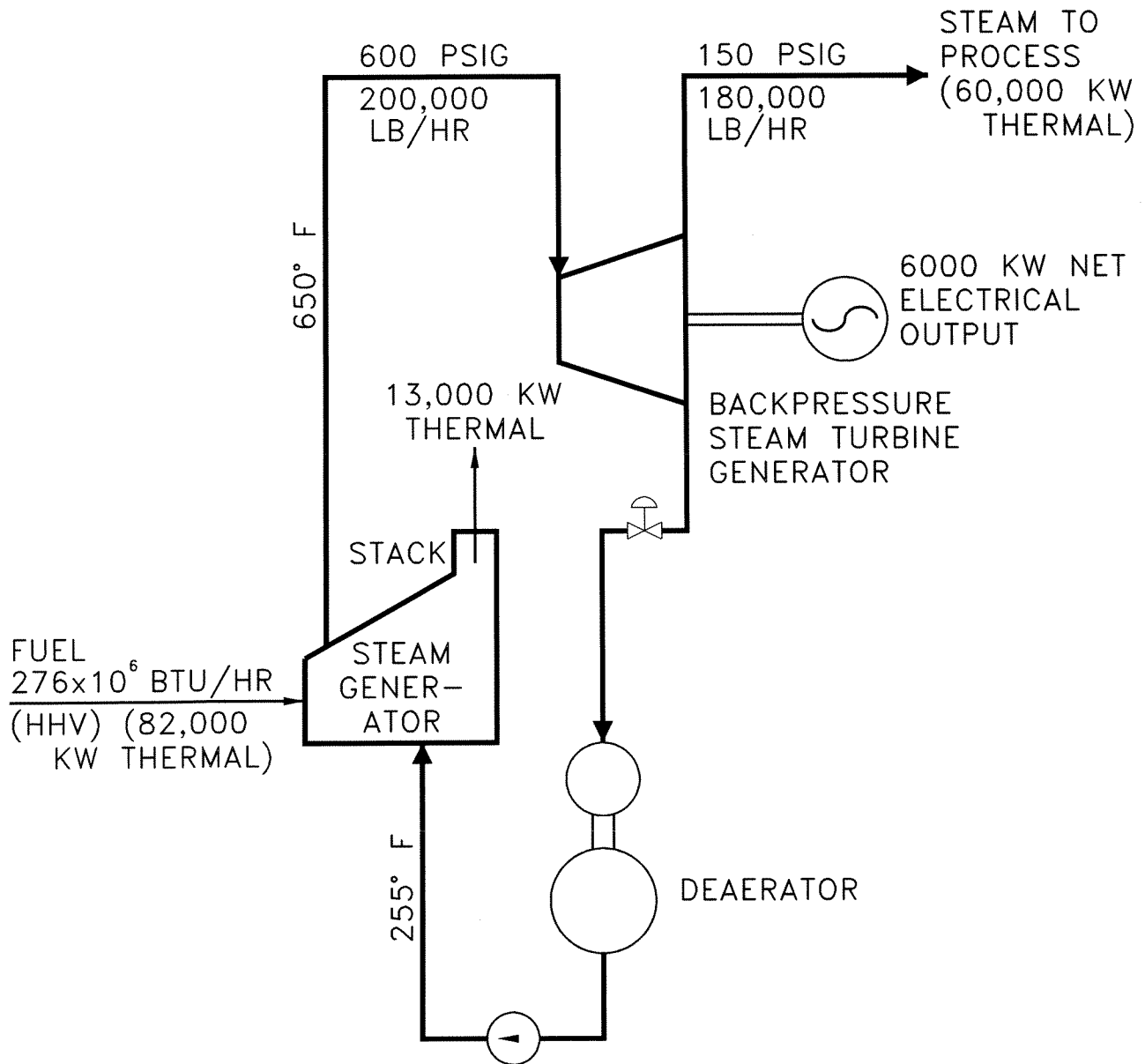

LOSSES AND AUXILIARY POWER = 3000 KW

$$\text{HHV THERMAL EFFICIENCY} = \frac{6000 + 60,000}{82,000} = 80\%$$

$$\text{HEAT/POWER RATIO} = \frac{60,000}{6000} = 10$$



GRYPHON  
INTERNATIONAL ENGINEERING SERVICES INC.

TYPICAL HEAT BALANCE  
ALUMINA PLANT APPLICATION

JAN. 2000

COGENERATION PRINCIPLES  
EXHIBIT 5

# STEAM GENERATOR/CONDENSING STEAM TURBINE

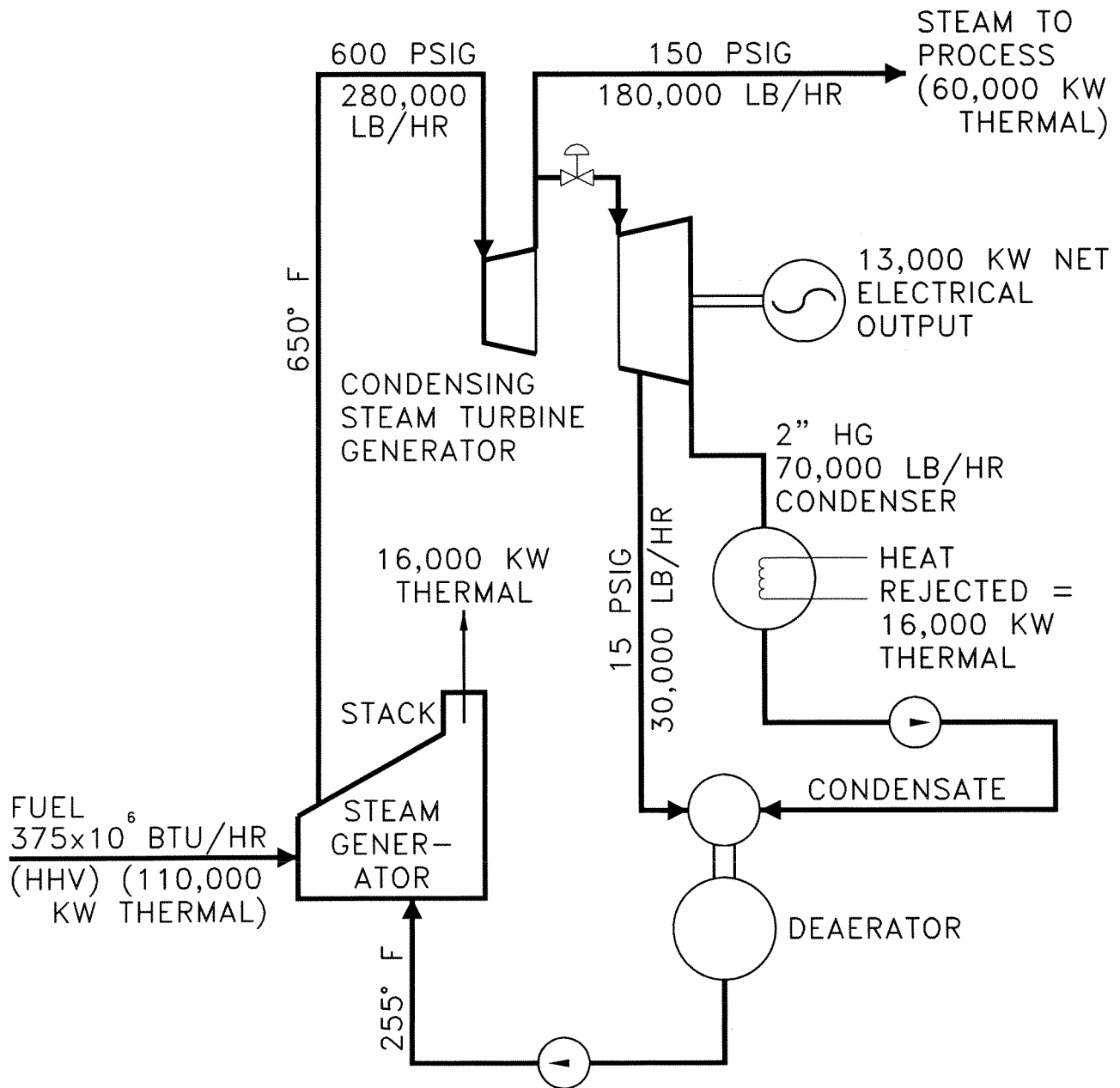

$$\text{HHV THERMAL EFFICIENCY} = \frac{13,000 + 60,000}{110,000} = 66.4\%$$

$$\text{HEAT/POWER RATIO} = \frac{60,000}{13,000} = 4.6$$



GRYPHON  
INTERNATIONAL ENGINEERING SERVICES INC.

TYPICAL HEAT BALANCE  
PULP & PAPER APPLICATION

JAN. 2000

COGENERATION PRINCIPLES  
EXHIBIT 6

# COMBINED CYCLE COGENERATION

STEAM HEAT TO PROCESS  
 = 12,600 + 7,800  
 = 20,400 KW THERMAL

NET ELECTRICAL OUTPUT  
 = 39,800 + 15,000  
 = 54,800 KW

LOSSES = 6,500 KW

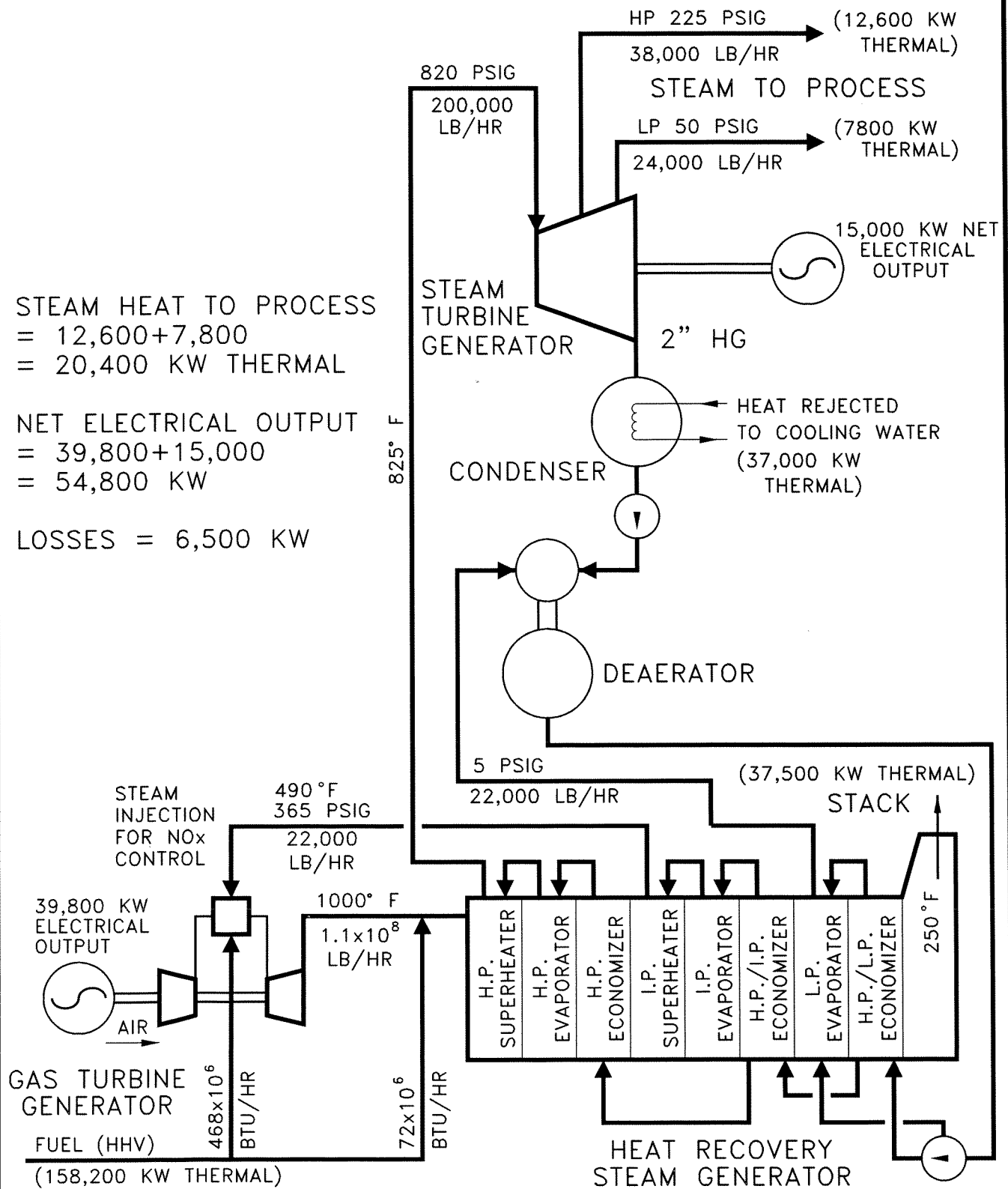

HHV  
 THERMAL =  $\frac{54,800 + 20,400}{158,200} = 47.5\%$   
 EFFICIENCY

HEAT/POWER =  $\frac{20,400}{54,800} = 0.4$   
 RATIO



**GRYPHON**  
 INTERNATIONAL ENGINEERING SERVICES INC.

## TYPICAL HEAT BALANCE COMBINED CYCLE APPLICATION

JAN. 2000

COGENERATION PRINCIPLES  
 EXHIBIT 7

# GAS TURBINE GENERATOR/HEAT RECOVERY STEAM GENERATOR

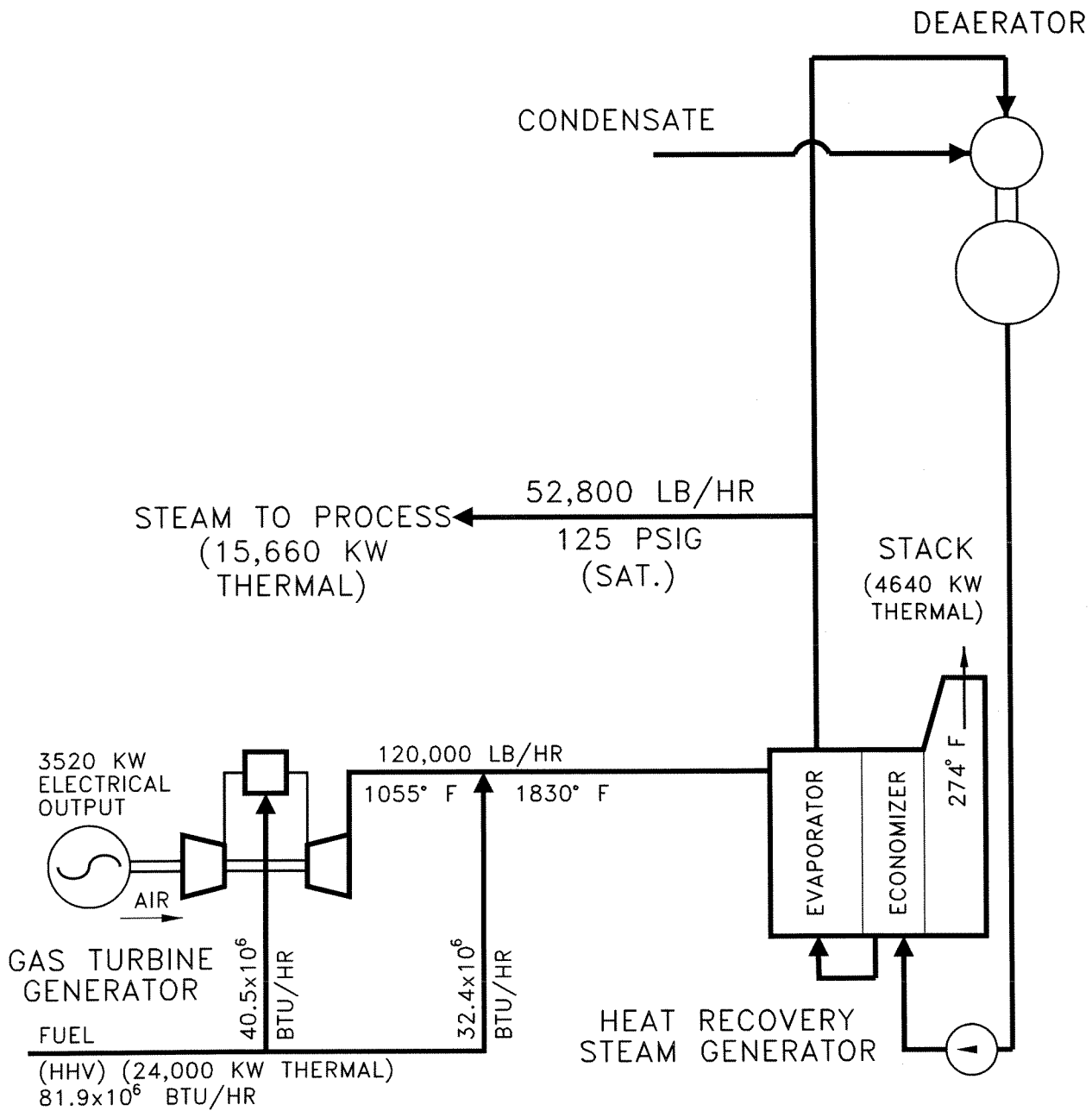

LOSSES AND AUXILIARY  
POWER = 600 KW

$$\text{HHV THERMAL EFFICIENCY} = \frac{3520 + 15,660}{24,000} = 80\%$$

$$\text{HEAT/POWER RATIO} = \frac{15,660}{3520} = 4.4$$



**GRYPHON**  
INTERNATIONAL ENGINEERING SERVICES INC.

TYPICAL HEAT BALANCE  
SMALL PROCESS PLANT APPLICATION

JAN. 2000

COGENERATION PRINCIPLES  
EXHIBIT 8

# COGENERATION EXAMPLE

## Existing – Base Case

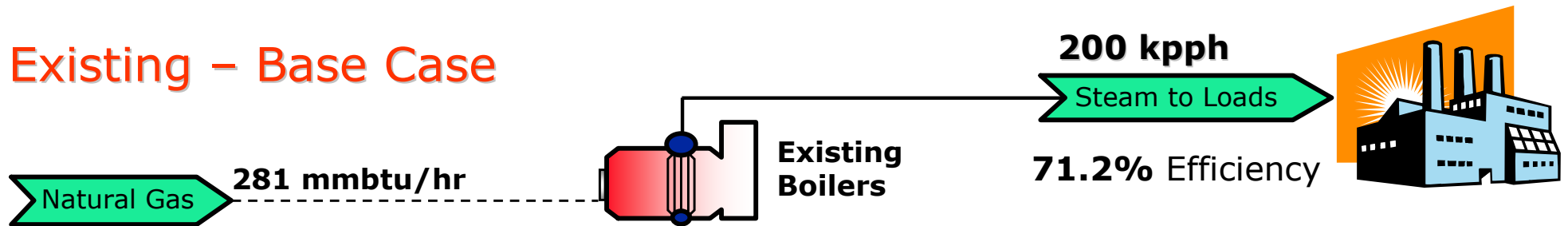

## Cogeneration Case

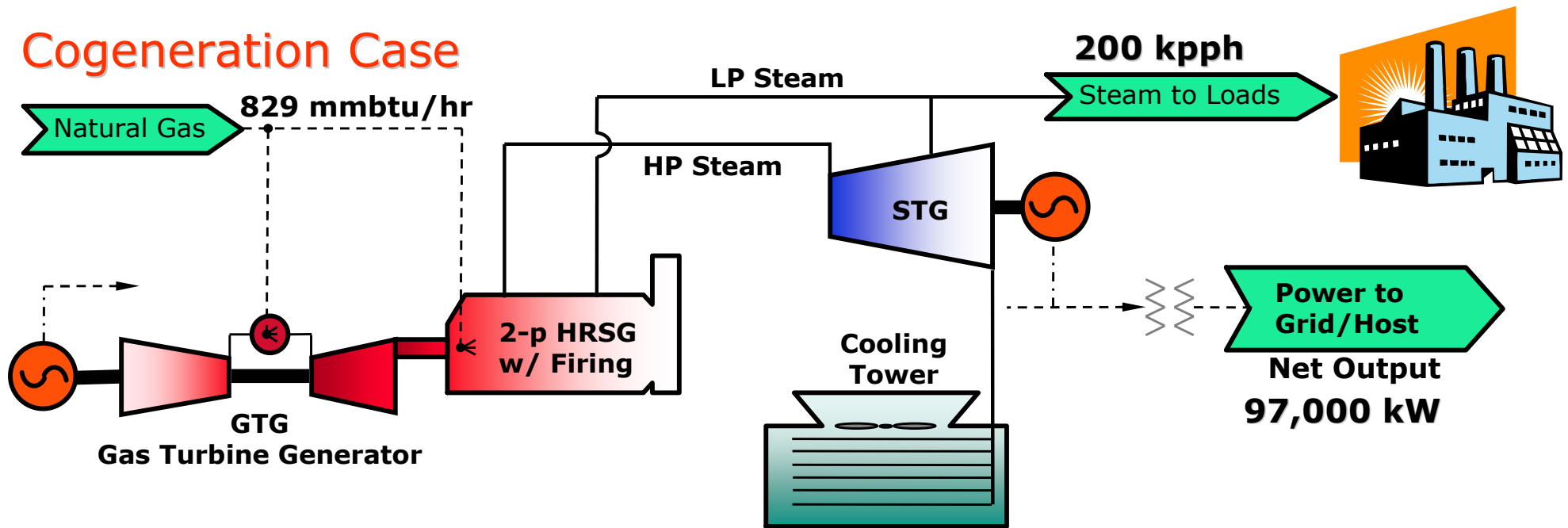

**Cogeneration or CHP Heat Rate**  
**5328** btu/kW.hr  
**64%** Efficiency

**FCP Heat Rate**  
**5650** btu/kW.hr  
**60.4%** Efficiency